



**JK part numbers:**  
J13641 and J13642

**OEM part number:**  
Not applicable

Page 1 of 5

# JK 'retro' driveaway frame awning

## Before you start

Thank you for purchasing our JK Retro frame awning. Please read these instructions to ensure a fault free time with your new awning.

- A trial set-up is essential before your intended journey, to check that all parts are included and that you are aware of the set-up procedure.
- Your awning should be set up on an even, clean surface, ideally with the front door facing downhill.
- Try to avoid opening onto hedges, large rocks or setting up directly under trees due to lightning danger, continued dripping after rain and falling tree debris.
- Tent pegs should be inclined away from the awning to achieve the best stability.
- Zippers should be closed during set up procedure. Please handle these with care, as these are wear and tear items that are not covered by the warranty.
- Do not touch the fabric when it is wet, as these touch points will become permeable and water will leak through. The thread contains some cotton which expands when wet, it is advisable to treat the seams with a seam sealer from time to time.
- Condensation may appear and should not be confused with water leakage. The risk of condensation can be reduced with proper ventilation, a roof condensation sheet is included.

## Putting away

To prevent mildew you should ideally dismantle the awning when it is completely dry. If this is not possible you should unpack your awning and dry as soon as possible. If packed away damp, you may need to re-waterproof the fabric before using it again.

Store your awning in a dry, cool and well ventilated place.



Available for left hand drive (J13642) and right hand drive (J13641) vehicles

## Maintenance

Use clean water for cleaning. For spots you can use an awning cleaner. NB: Awnings should never be washed in the washing machine or treated at a dry cleaning agent.

Poles must be stored clean and dry.

Zippers should be treated with Zip Ease from time to time.

Please keep this information for future reference and pay careful attention to the instructions. This will prolong the working life of your awning.

## Awning tie down kits

We recommend that you use an awning tie down kit to prevent damage in adverse weather. Damage caused by weather conditions is not covered under warranty.

## Fire safety

Do not use cookers, stoves, heaters or lamps close to the awning canvas.

Always read the fire drill instructions where you are staying and know where extinguishers are on site. We recommend for extra safety, carrying your own extinguisher.



JK part numbers:  
J13641 and J13642

OEM part number:  
Not applicable

Page 2 of 5

### The awning kit contains:

1x awning material, 1x groundsheet, 1x inner tent, 1x roof condensation sheet, 2x curtains, (a)=74x plastic groundsheet pegs, (b)=3x gutter clamps, (c)=1x centre pole, (d)=2x side poles, (e)=4x 25mm diameter curved roof poles, (f)=2x 22mm diameter curved roof poles, (g)=4x adjustable leg poles, (h)=2x 'L' shaped poles, (i)=2x sun canopy poles, (j)=1x vehicle gutter pole, (k)=40x metal tent pegs, (l)=1x 'T' shaped pole.

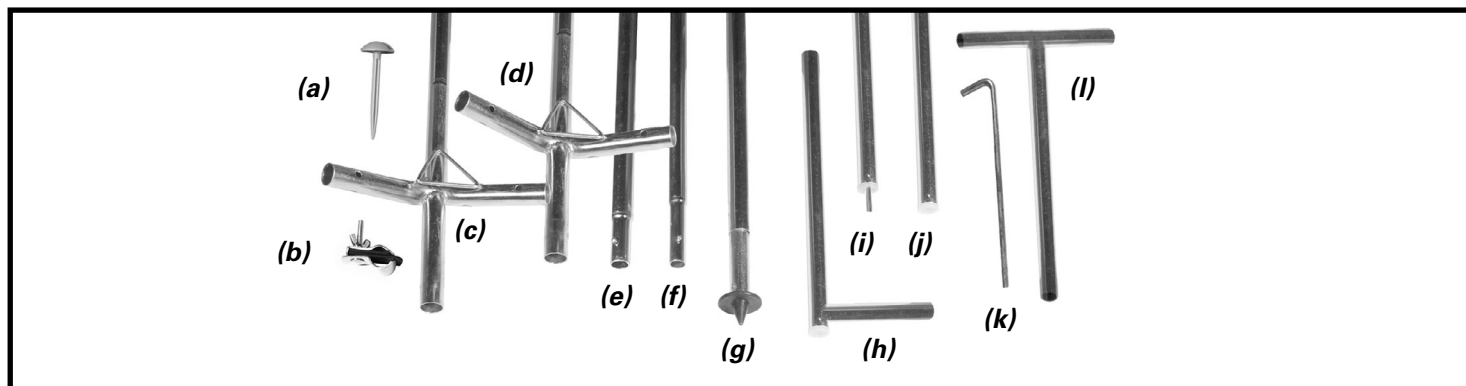

### Step One

Firstly, on the left is an exploded view of all the main awning poles in their correct positions. This part of the awning requires the four 'curved' 25mm diameter roof poles (e). After pushing all of these poles together you should end up with the basic frame of the awning.

Note: Keeping the legs on their shortest setting at this stage will make fitting the awning material much easier.

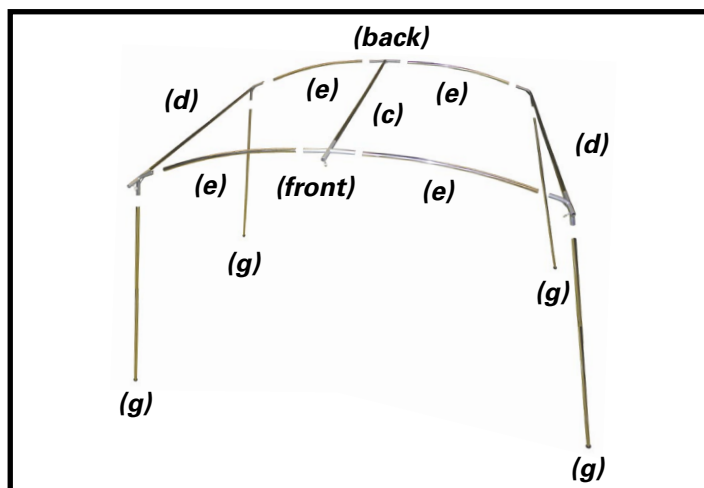

1. Assemble main awning poles

### Step Two

The next step is to lay the awning material over the top of the frame.

Starting at the front of the awning, there are three holes in the material which correspond with three protruding frame poles. Once the three short poles are pushed through the matching holes in the material you can pull the remaining fabric over the frame.



2. Lay awning material over the top of the frame



JK part numbers:  
J13641 and J13642

OEM part number:  
Not applicable

Page 3 of 5

### Step Three

After fitting the material, you can extend the legs which have three height settings.

The ideal height is one where the awning material can be pegged to the ground securely without placing too much strain on the fabric or the poles.

Once you are happy that the material is fitted correctly you can tie it to the frame legs. Inside the awning there are eight ties, two in each corner.

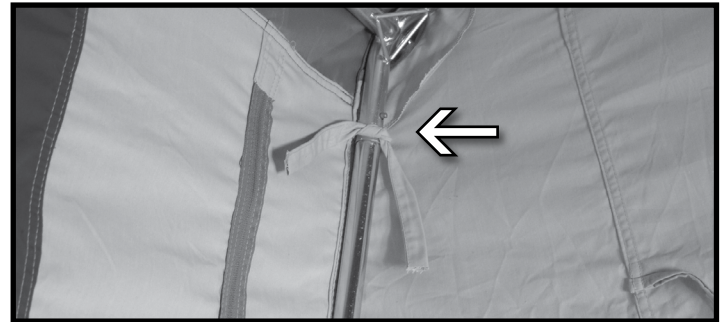

3. Tie the material to the frame legs

### Step Four

The overhang poles above, (l), (f) and (h) can now be fitted together and then clamped onto the front of the frame that you made earlier.

The roof material can now be pulled over this frame and the two are held together with velcro strips.

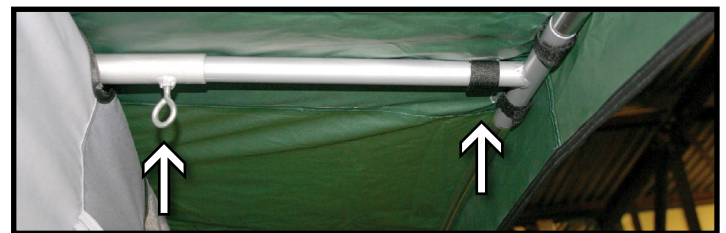
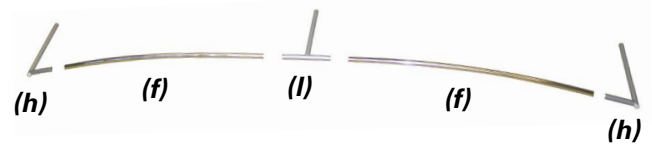

4. Attach overhang and fix roof material with velcro strips

### Step Five

Now the awning can be pegged to the ground.

The steel pegs (k) are used on the elasticated loops around the base of the material which are hidden underneath the black awning skirt.

There is an inner skirt and an outer skirt, both of which are pegged down using the plastic pegs (a).

Six steel pegs are also used for pegging out the guys, three each side.

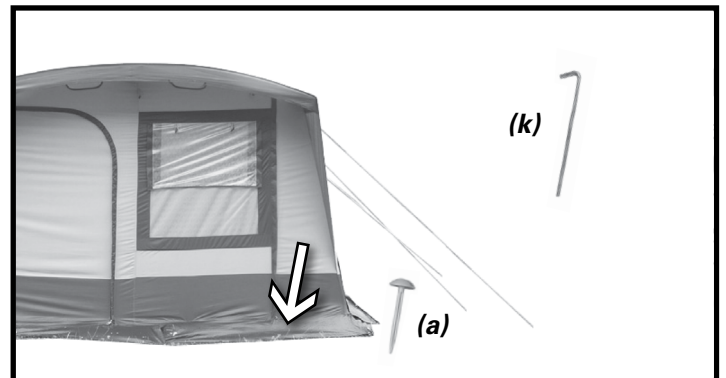

5. Peg the awning to the ground and peg out the guys

### Step Six

The ground sheet can now be placed inside the awning and pegged down using the remaining plastic pegs (a).

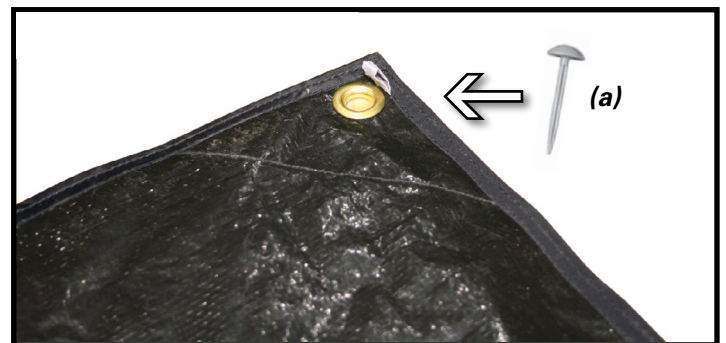

6. Peg down the ground sheet inside the awning



JK part numbers:  
J13641 and J13642

OEM part number:  
Not applicable

Page 4 of 5

### Step Seven

Next to fit is the roof condensation sheet, this clips to the ceiling and helps to protect the occupants from any overnight condensation that may form.

The plastic clips fasten in the centre of the frame and in each corner.

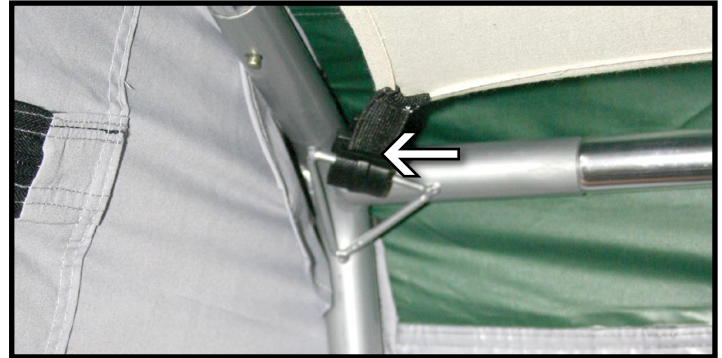

7. Clip the roof condensation sheet onto the frame

### Step Eight

Once the condensation sheet is in, the next is to fit the inner tent.

The top of the inner tent clips to the ceiling in the same way as the condensation sheet.

The bottom of the inner tent has four hooks which hook onto four loops on the ground sheet.

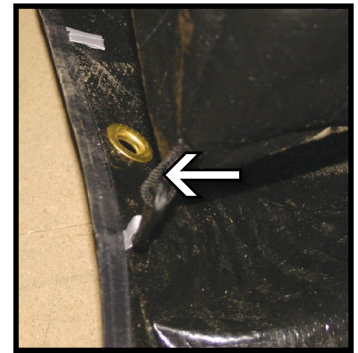
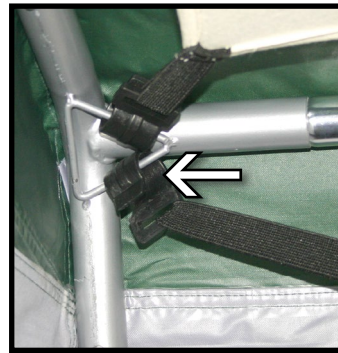

8. Clip inner tent to frame and hook onto ground sheet

### Step Nine

To attach the awning to the vehicle, slide the gutter rail (j) through the sleeve in the awning material and then place the 3 clamps (b) along the length of the rail.

This rail then sits in the vehicles gutter and the clamps are fitted to the vehicle as shown.

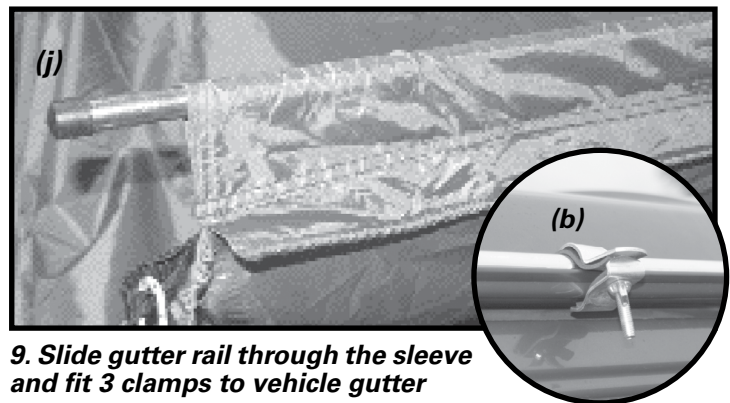

9. Slide gutter rail through the sleeve and fit 3 clamps to vehicle gutter

### Step Ten

Finally, you can convert the side panel to a sun canopy simply by adding the two sun canopy poles (i) and spare guy ropes.

This will provide you with a sun shade.

NOTE: This should only be used in calm, dry conditions!



10. Convert the side panel to a sun canopy using poles



**JK part numbers:  
J13641 and J13642**

**OEM part number:  
Not applicable**

**Page 5 of 5**

**justKAMPERS.COM**  
**Tech Sheet**

## **Quick user guide**

- 1. Keep all doors zipped shut when pegging out the awning and guy ropes.**
- 2. Ensure all guy ropes and pegging points are used and that the awning is correctly adjusted and the material taut.**
- 3. Do NOT touch the inside of the awning material when wet. As the oil on your skin will affect the waterproofing.**
- 4. In windy conditions, check and adjust guy ropes and pegging regularly.**
- 5. Do NOT pack awning material away wet, as this will cause mildew to form. If you do have to pack a damp awning, hang it up and air as soon as possible.**



**[www.justkampers.com](http://www.justkampers.com)**  
**01256 862288**

**Just Kampers, Unit 1 Stapeley Manor, Long Lane, Odiham, Hants. RG29 1JE**

**NB. Please note that whilst every attempt is made to ensure that these instructions are as accurate and clear as possible, we cannot be held responsible for misinterpretation of these instructions or for any subsequent accident or damage caused through mis-fitted parts.**